

ASSEMBLY INSTRUCTIONS & PARTS MANUAL

36" High Standard Storage Cabinet Unassembled Models 1436 & 2436



RETAIN INSTRUCTIONS FOR FUTURE REFERENCE



LOAD CAPACITIES PER SHELF LEVEL EVENLY DISTRIBUTED	
UNIT SIZE	WEIGHT CAPACITY
36w x 18d	200 lbs.
36w x 24d	200 lbs.

GENERAL SAFETY INFORMATION

Some parts may have sharp edges. CARE must be taken when handling various pieces to avoid injury. For safety, wear a pair of work gloves when assembling or performing any maintenance on products.

LIMITED WARRANTY

Tennsco warrants goods purchased hereunder to be free of defects in materials and workmanship for a period of one (1) year from the date of shipment, hereunder. This warranty shall not apply in the event goods are damaged as a result of misuse, abuse, neglect, accident, improper application, modification or repair by persons not authorized by Seller, where goods are damaged during shipment, or where the date stamps on the goods have been defaced, modified or removed. UNLESS CONSIDERED UNENFORCEABLE OR UNLAWFUL UNDER APPLICABLE LAW:

- a. ALL IMPLIED WARRANTIES, INCLUDING BUT NOT LIMITED TO WARRANTIES OR MERCHANTABILITY AND FITNESS FOR A PARTICULAR PURPOSE ARE HEREBY EXCLUDED:
- b. BUYERS REMEDY, IF ANY, FOR ANY DEFECTIVE GOODS SHALL BE LIMITED TO A REFUND BY SELLER OR REPLACEMENT OF THE GOODS AT SELLER'S OPTION, AND SHALL IN NO EVENT INCLUDE DAMAGES OF ANY KIND, WHETHER INCIDENTAL, CONSEQUENTIAL OR OTHERWISE.

NO GOODS ACCEPTED FOR RETURN WITHOUT PRIOR APPROVAL. Seller shall have the right to inspect any goods claimed to be defective at Buyers place of business or require Buyer to return the goods to Seller for inspection on Seller's premises. Transportation charges covering returned goods will be borne by Seller only if such goods are proven to be defective, are covered by this warranty and are returned within the warranty period stated above.



PROUDLY MADE IN THE U.S.A.

Tennsco LLC., Dickson, TN 37056-1888 • (866) 446-8686

ASSEMBLY OF 1436 OR 2436 CABINET

Tools Needed: A free 11/32" nut driver is included with each Tennsco cabinet.
Two people are recommended for assembly. Approximate assembly time: 20-30 minutes.

1. The reference numbers used throughout this sheet refer to the illustration on the back cover. This is to help you to identify the various parts as they are mentioned.
2. Place the cabinet back (Ref. No. 1) on a protected surface to prevent scratching the paint. The flange on the bottom of the back should be facing upward.

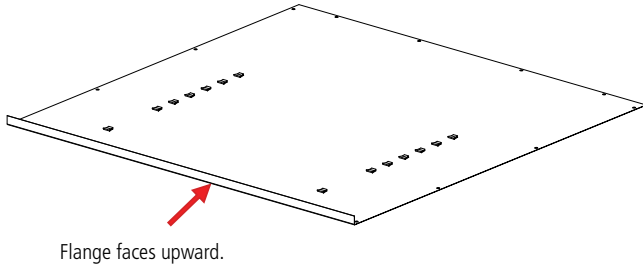

3. Attach the left side (Ref. No. 2) to the back by placing flange (A) around the back and bolting the back and side together with four bolts and nuts (Ref. Nos. 17 & 18). Be sure that the lances on all shelf adjustment strips (B) point in the same direction.

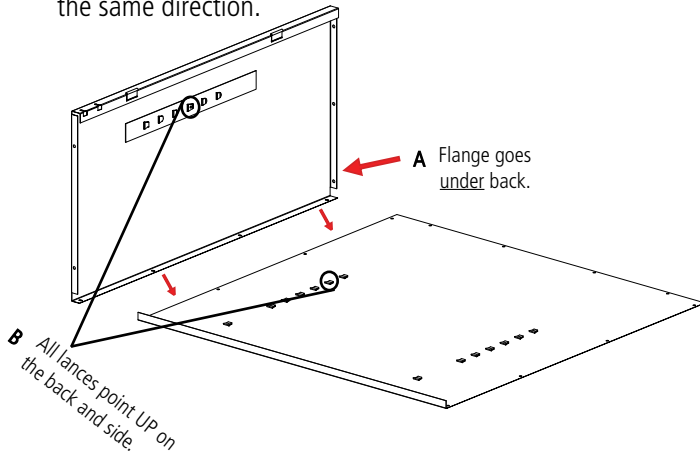

4. Attach the top (Ref. No. 5) to the unit by sliding the outer flange over the back of the unit and the side flange to the side panel on the unit. The threaded studs should go through the holes in the top flange of the side and fasten with three nuts. Attach the back to the top using four bolts and nuts.

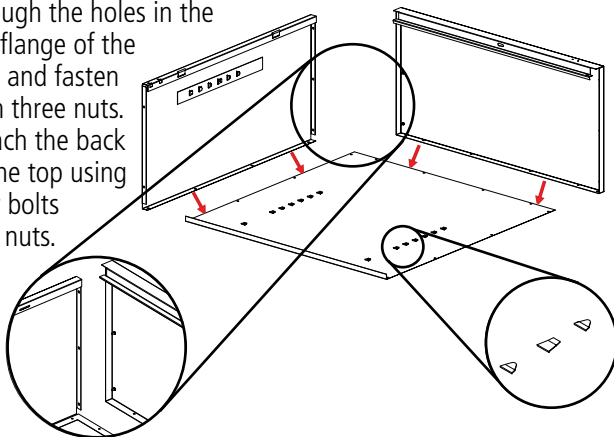

5. Attach the right side (Ref. No. 3) to the back in the same manner as you did in step 3, again making sure that the flange is around the back and that the lances on the shelf adjustment strips are pointed in the same direction as those on the back and left side. Push the side panel up so the studs in the top go through the holes in the top flange of side and fasten with three nuts.

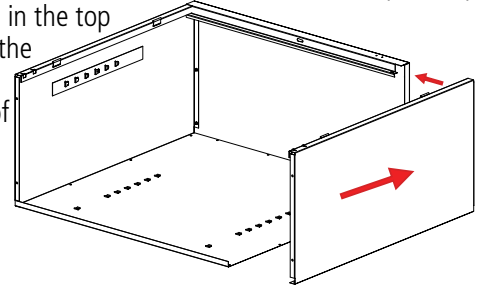

6. Attach the sill (Ref. No. 6) to the sides. Place nuts loosely on each of the studs and slide the ends of the sill into the slots on both sides of the unit. Then, securely tighten the nuts.

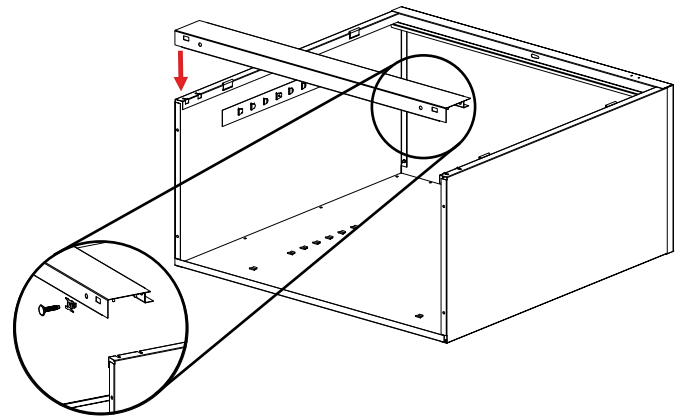

7. Place the rear flange of the bottom (Ref. No. 9) into the bottom lances of the back. The flange with two holes should face the front, hanging over the sill. Insert bolts through the bottom and sill with the head facing the front of the unit. Secure with two nuts.

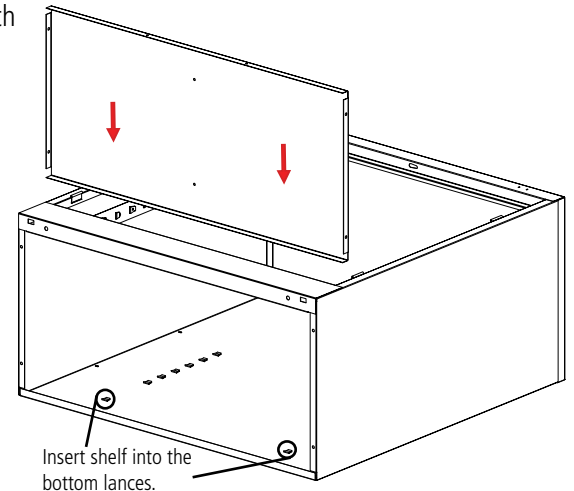

8. Set the unit upright and tighten all the nuts and bolts around the entire unit.

9. Insert the shelves (Ref. No. 4) at the desired levels.

NOTE: In order to place the shelves, you must first tilt the shelf slightly to the left or right before inserting it into the unit.

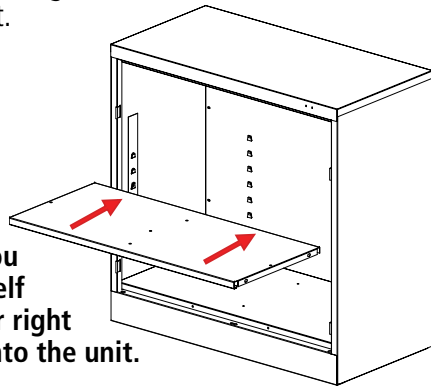

10. Attach the left door (Ref. No. 7) to the unit by placing the door on the hinges, aligning the hinge holes, dropping the pins into the slots, then placing the flat end of a screwdriver on the hinge pins (Ref. No. 15) and tapping them in with a hammer.

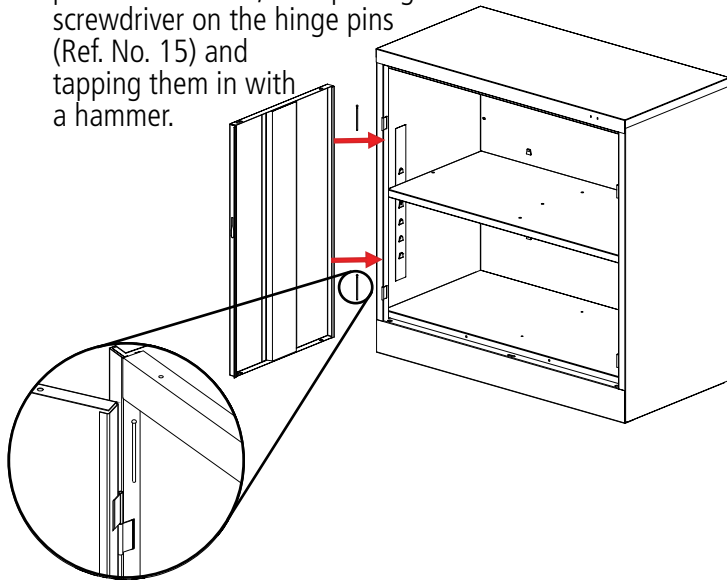

11. Attach the right door (Ref. No. 8) to the unit in the same way you attached the left door.

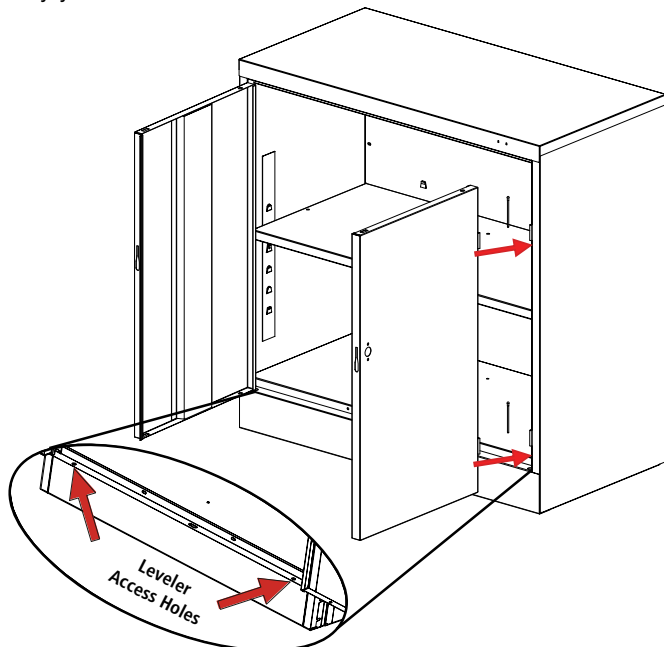

12. The cabinet must be level in order for the doors to close properly. Levelers may be adjusted by placing the nut driver through the hole in each end of the sill and adjusting the leveling screw.

Handle/Locking System Installation

1. Place the locking handle (Ref. No. 11) on the right hand door and fasten with two #8-32 X 1/4 hex-head bolts and lock washers, provided with the handle.

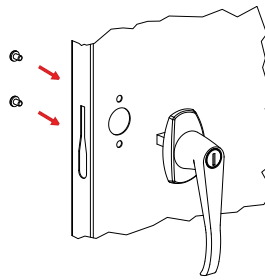

2. Turn the handle to the open position and place the locking cam (Ref. No. 12) over the square shank of the door handle. The latch must be facing downward as shown. Then place the locking cotter pin (Ref. No. 14) through the hole of the square shank.

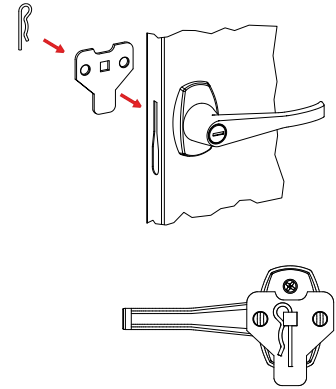

3. With the handle still in the open position, hook the locking bars (Ref. No. 10) to the locking cam (see "A" at left). Once in position, slowly rotate the door handle to the closed position so the lock bars protrude from the holes at the top and bottom of the door (shown at right, below).

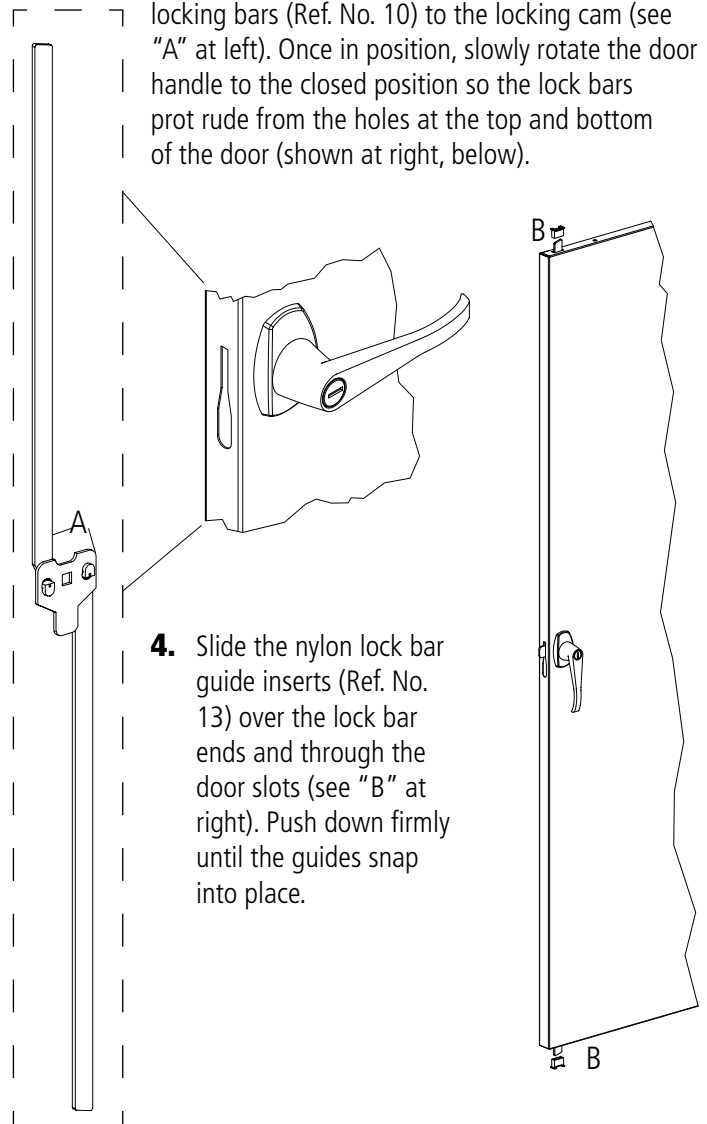

4. Slide the nylon lock bar guide inserts (Ref. No. 13) over the lock bar ends and through the door slots (see "B" at right). Push down firmly until the guides snap into place.

REPLACEMENT PARTS

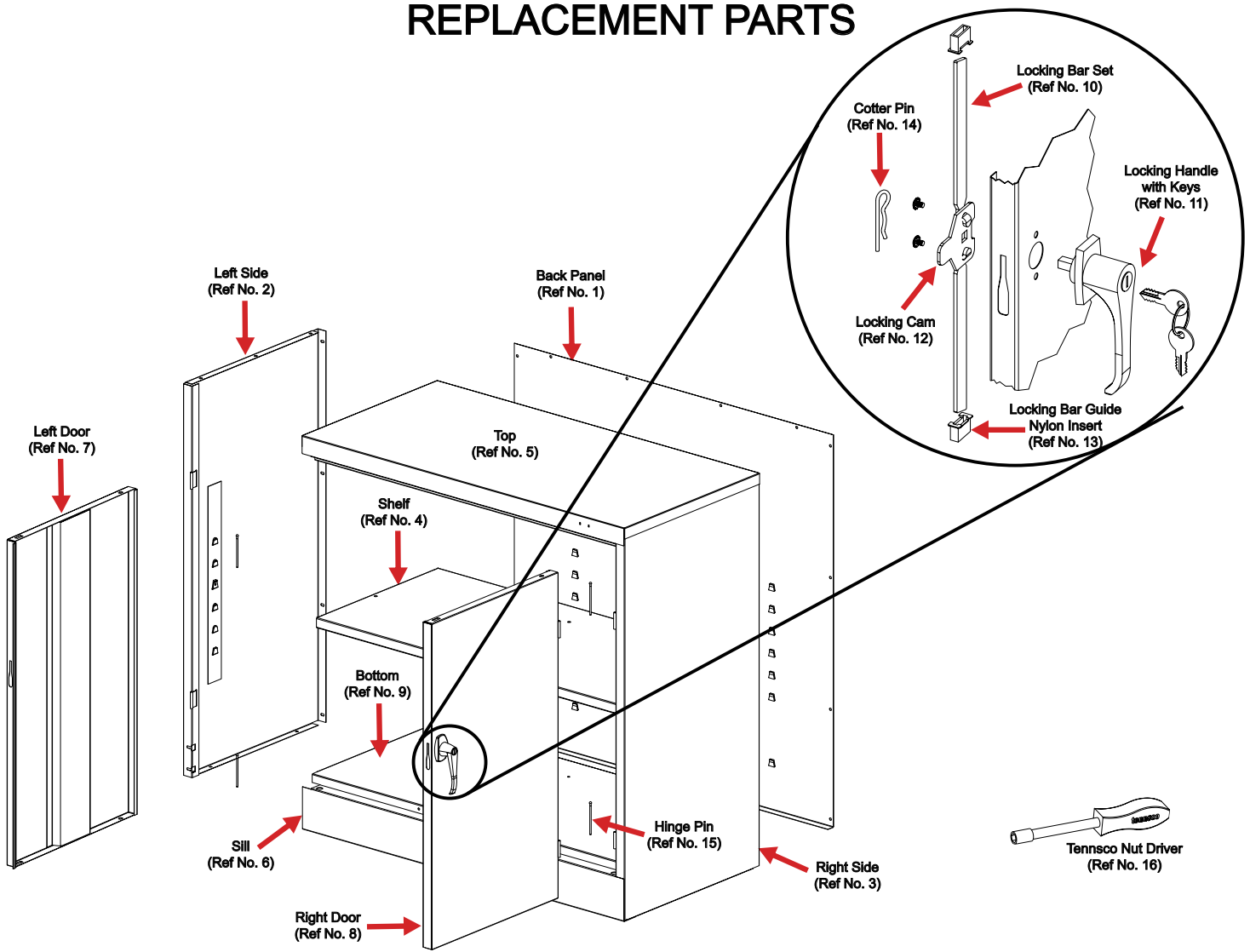

REF. NO.	DESCRIPTION	QTY.	PART NO.	
			1436	2436
1	Back Panel	1	036BA	036BA
2	Left Side	1	LS1436	LS2436
3	Right Side	1	RS1436	RS2436
4	Shelf	1	301	302
5	Top	1	978CT	292TO
6	Sill	1	944SI	944SI
7	Left Door	1	036LD	036LD
8	Right Door	1	036RD	036RD
9	Bottom	1	944BO	292BO
10	Locking Bar Set	1	036LB	036LB
11	Locking Handle w/keys & hardware	1	944LH	944LH
12	Locking Cam*	1	944LC	944LC
13	Locking Bar Guide Insert (Nylon)*	2	944GI	944GI
14	Cotter Pin*	1	CTRPN	CTRPN
15	Hinge Pin*	6	944HP	944HP
16	Tensco Nut Driver	1	TOOL-2	TOOL-2
17	#8-32 x 3/8" bolts (not shown above)	14	**	**
18	#8-32 nuts (not shown above)	24	**	**

*Included in Ref. No. 11, locking handle with keys and hardware (Part No. 944LH).

**Available Locally

NOTE: Additional hardware may be included for replacement purposes.

Tensco makes every effort to ensure that all units ship complete with all parts and arrive undamaged. However, should your unit contain missing or damaged parts, please contact your purchase location.